

RACK SPECIFICATIONS

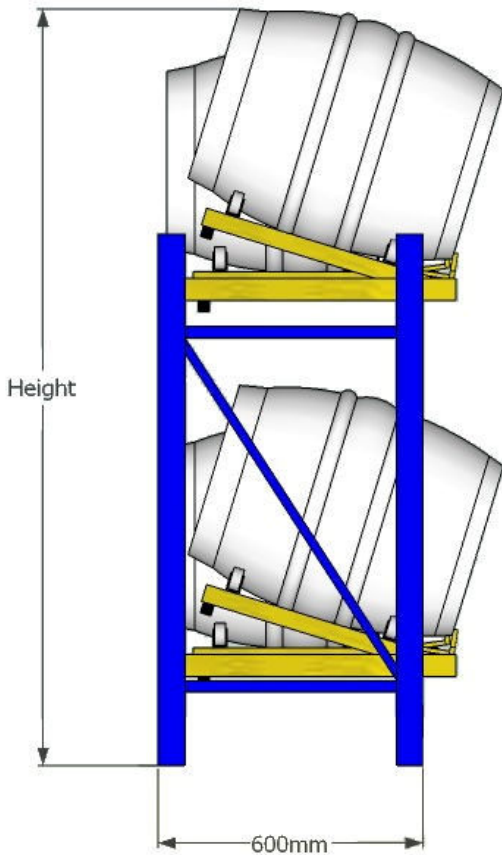

- ◆ **CASK RANGE**
Suitable for all size casks from 9 to 22 gallons
- ◆ **PROTECTIVE FINISH**
Stillages – Zinc plated on all mild steel components
Racks – Powder Coat Blue on top of ion phosphate coating.
- ◆ **TILT ANGLE**
All stillages tilt to a 20° angle (variable)
- ◆ **TILTING MECHANISM**
Systems can be supplied with either mechanical spring or hydraulic spring stillages.

RACK WIDTH

All racks are 600mm deep.
A minimum distance of 1200mm is required in front of the rack to operate a lift truck.

CEILING HEIGHT REQUIREMENTS

Where both levels of casks are raised from the cellar floor the minimum heights required are shown below.

Two Tier 9 gallon casks	1565mm
Mixture of 9 & 18 gallon casks	1665mm
Two Tier 18 gallon casks	1765mm

The standard height of a Kayel Lift Truck is 1700mm although the height can be reduced if the ceiling height is below this dimension

RESTRICTED CEILING HEIGHT

In cellars with low ceiling heights, systems can be supplied with the lower level of casks on Floor Standing Stillages.
This reduces the overall height as below.

Two Tier 9 gallon casks	1415mm
Mixture of 9 & 18 gallon casks	1515mm
Two Tier 18 gallon casks	1615mm

RACK LENGTHS

Racks can be supplied in standard lengths to suit up to 18 gallon casks as listed below.

3 up 3 down Rack – 1750mm	7 up 7 down Rack – 4000mm
4 up 4 down Rack – 2300mm	8 up 8 down Rack – 4550mm
5 up 5 down Rack – 2850mm	9 up 9 down Rack – 5100mm
6 up 6 down Rack – 3450mm	10 up 10 down Rack – 5650mm

Where racks are to be used solely for 9 or 22 gallon casks, standard rack lengths can be reduced or increased.

Both larger and smaller racks can be supplied in addition to those listed above.

Kayel Brewery Supplies Limited

Unit 14, Lawson Hunt Industrial Park, Broadbridge Heath, Horsham, West Sussex, RH12 3JR

Tel: (01403) 261026

Fax: (01403) 217340